



ZoneSafe RFID Detection System User Manual

Control Unit – ZS-1000-ECU/ZS-1001-ECU(NA)

Antenna – ZS-1000-AP/ZS-1001-AP(NA)

Document Name
ZoneSafe User Manual
Document Number
ZS-1000-UM
IG PN 6133

Contents

1.	How To Use This Manual	4
2.	Introduction	4
3.	RFID System Components	5
4.	Control Unit	5
	4.1 What's In The Box	6
	4.2 Specification	6
	4.3 Control Unit Installation	6
	4.4 Installation Considerations	7
	4.5 Removal of tamper cover located at the bottom of the Control Unit	7
5.	Antenna Unit	7
	5.1 What's In The Box	7
	5.2 Specification	7
	5.3 Antenna Unit Installation	8
	5.4 Installation Considerations	8
	5.4.1 Antenna Unit Mounting	8
	5.4.2 Distance Between Antenna Units	9
	5.4.3 Optimum Tag Position	9
	5.4.4 Antenna Unit Example Installation Positions	10
6.	Fixings	10
	6.1 AMPS Hole Configuration	11
	6.2 Adaptor plates	11
7.	System Wiring - Schematic	12
	7.1 Antenna Unit Wiring	13
	7.2 Antenna Unit Switches	13
8.	Wi-Fi Configuration & Settings	14
	8.1 Control Unit Connection	14
	8.2 Summary	14
	8.3 View & Change Settings - Control Unit	15
	8.4 Settings & Information - Antenna Unit	15
9.	RFID System Operation	16
	9.1 On Sequence	16
	9.2 Off Sequence	16
	9.3 Control Unit Diagram & Alarm Details	17
	9.4 Types of Alarms	17
	9.5 Setup of the Antenna Unit	17
10.	Troubleshooting	18
11.	System Units Care	18
12.	Disclaimer	19

Information in this document is subject to change without notice. You do not have permission to reproduce, publish or share any part of this document either electronically or printed in part or full without prior written consent from Brigade Electronics.

Disclaimer / Best Practice

The ZoneSafe RFID Detection System is not a protective device, it does not initiate or perform safety related functions and it does not provide control to reduce risk.

ZoneSafe should not be used to replace proper job site organisation, safeguards, operator training and the application of relevant vision standards that addresses safety and the safety of people on job sites.

1. How To Use This Manual

This manual will guide you through the installation and configuration of our RFID Detection systems.

It will show you how and where to position the system units, enabling you to get the best possible performance from our product.

2. Introduction

Our active RFID Detection System comprises of one Control Unit and one or more 'Function Units'. This manual will instruct on best practice for placement of equipment, attachment methods and wiring.

Glossary of terms:

Function Unit : A generic term for the detection units in our system, i.e. Antenna Unit.

Control Unit : This creates visible & audible alerts to the user when either a pedestrian or static object with a tag. All Function Units are wired to the Control Unit and every system requires one.

Detection Zone : Imagine an invisible sphere whose centre point is a Function Unit. When we indicate a range for a Function Unit it means from the centre point of the unit itself, not from the edge of the vehicle. This is why correct installation is the key to getting a system to perform the way you want it to.

Antenna Unit : This is the vehicle mounted Function Unit which detects our active tags and any of our other products that act like tags. The Antenna Unit is primarily fitted when we wish to detect proximity of pedestrians wearing our tags. The range is adjustable from 3-10m/10'-33', measured from the Detection Zone centre point. The Antenna Unit does not need a clear line of sight.

Tags : Our active RFID tags are detected by the Antenna Unit and are compatible with other products such as the Tag Tester which can be used for tasks such as access control or pedestrian monitoring, for example.

NOTE: ZoneSafe must be fitted and commissioned by an approved installer. No responsibility will be accepted for damage to systems caused by incorrect installation or misuse. Detection accuracy will depend on environmental and installation factors.

Overview of a typical vehicle system installation

Read the sections of this manual which instruct how to install the specific system items and best positioning for the optimal performance. Then you can proceed to installation.

1. Decide where you will fit your ZoneSafe Units to give the detection zone you require, by following the guidelines set out in this manual.
2. Decide on fixings to keep the ZoneSafe Units in place (fixings, mounting plates etc.).
3. Make a note (or take a photo) of the label on the back of the Control Unit, as you will need the serial number for connecting over Wi-Fi. Then you can fix the units in their final position.
4. Identify the vehicle connections.
5. Isolate the vehicle power supply before wiring the system.
6. Wire the Control Unit to the vehicle, ensuring to make the mandatory connections, then any optional connections required.
7. Connect the Control Unit to the first Function Unit (e.g. Antenna) using the cable specified (see Control Unit Connection section). Set the first Function Unit address switch to 1.
8. Connect the first Function Unit to the second (if using more than one), and set this unit's address switch to 2. Now do the same for a third unit and so on, until all the Function Units are connected.
9. When you reach your last Function Unit, fit the blanking plug to the unused hole in the enclosure to ensure a weathertight seal. Make sure all of your Function Units are screwed shut and the glands are tight.
10. Now you can connect the vehicle power source. Stand near the Control Unit and connect using Wi-Fi direct on a mobile device to configure your system.
11. Test your system works exactly the way you would like before finishing installation.

3. RFID System Components

The ZoneSafe RFID Detection System consists of a Control Unit and a number of Function Units. Tags are required for any system which uses Antenna Units. For a more comprehensive range of our products please contact our sales team.

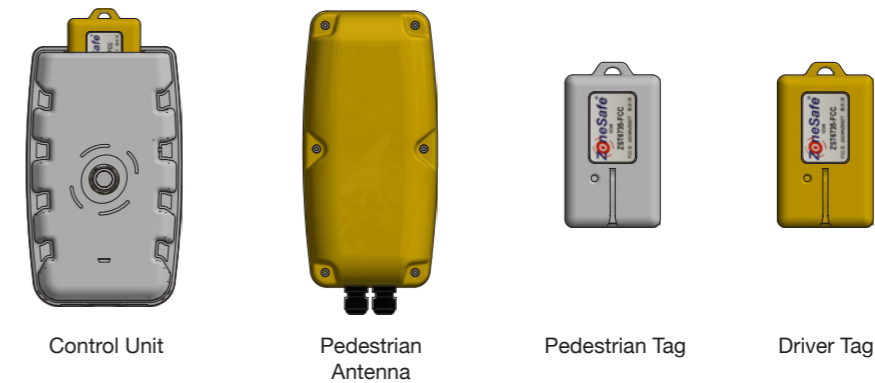

NOTE: Tags can be masked by other objects (e.g. mobile phone) so always ensure when using the product (e.g. carrying it in a pocket) it's placed on its own. Active tags are an integral part of an Antenna Unit system and are typically required for a system to work. There are multiple options for tags, and all are purchased separately. Please refer to Tag Manual for a more comprehensive guide.





4. Control Unit

The Control Unit controls one or more of the system's Function Units and acts as the user interface. The unit contains a battery backed real-time clock for time stamping events, internal memory to store event data and a Wi-Fi module for communication. A built in relay is available for additional external sounders or beacons.

The Control Unit is mounted in the driver cab next to the operator so it can be clearly visible at all times. Audible alerts are emitted from a sounder located on the front, and a light panel and button create visual alerts and indicate various alarm states. The button can be configured to acknowledge the detection of one or more tags or vehicles and mute them if required.

4.1 What's In The Box

Listed below are all components included in a ZoneSafe Control Unit.

ZoneSafe Control Unit Components			
			
ZoneSafe Control Unit (x1) Part No: 5881	Cable Loom & Connector (x1)	Inline Fuse Holder (x2)	7.5 Amp Blade Fuse (x2)

4.2 Specification

Listed below are the ZoneSafe Control Unit specifications.

ZoneSafe Control Unit			
Electrical	Voltage Current Consumption Memory	12V - 24V DC nom (11-32V max) 1A max 4000 Events 1A @ 12volts (any additional antennas add 1A @ 12Volts)	
Mechanical	Dimensions (incl. glands) Material Weight Connectors Relay (for additional sounders / beacons) Digital Input	180 x 102 x 58mm/ 7" x 4" x 2.3" (7" x 4" x 2 ⁵ / ₁₆ ") ABS 0.5kg IP D-type N/O N/C 0.5A @125VAC, 2A@ 30VDC 3 x Opto-Isolated inputs	
Communications	Wi-Fi	IEEE 802.11b/g/n (2.4GHz)	
Environment	Ingress Protection Temperature	IP65 -40°C to +85°C/ -40°F to 185°F	

4.3 Control Unit Installation

The Control Unit should be installed in the vehicle cab, within the machine driver / operator's view and within reach to ensure that they can press the mute button on the front of the Control Unit.

It can be installed using a number of different fixing methods (see 7. Fixings section for further information). Note - The cable assembly will need to be plugged into the bottom of the Control Unit. Once slotted in, remember to tighten up the screws on either side of the plug.

The tamper cover should arrive with you **not** fitted. However, if you need to remove it once fitted, please see the instruction diagram on the following page.

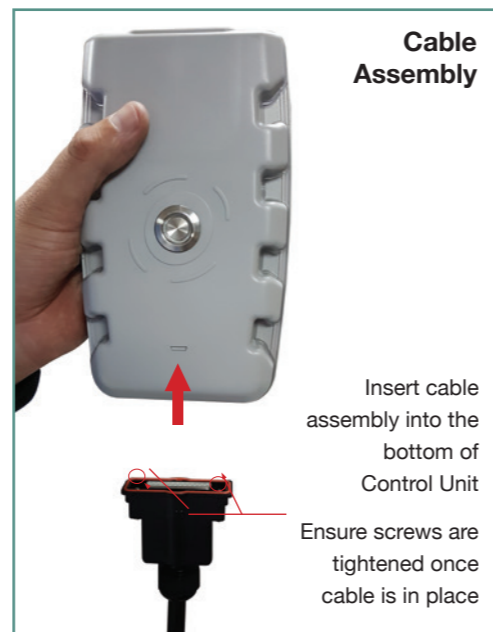

4.4 Installation Considerations

- The Control Unit should **NOT** be any closer than 200mm/8" to the operator.
- The Control Unit and Antenna Unit **MUST** be spaced at least 750mm/30" apart.
- The Control Unit should always be installed so the tag slot faces upwards. A forward or backward tilt of up to 45 degrees is allowable.

4.5 Removal of tamper cover located at the bottom of the Control Unit

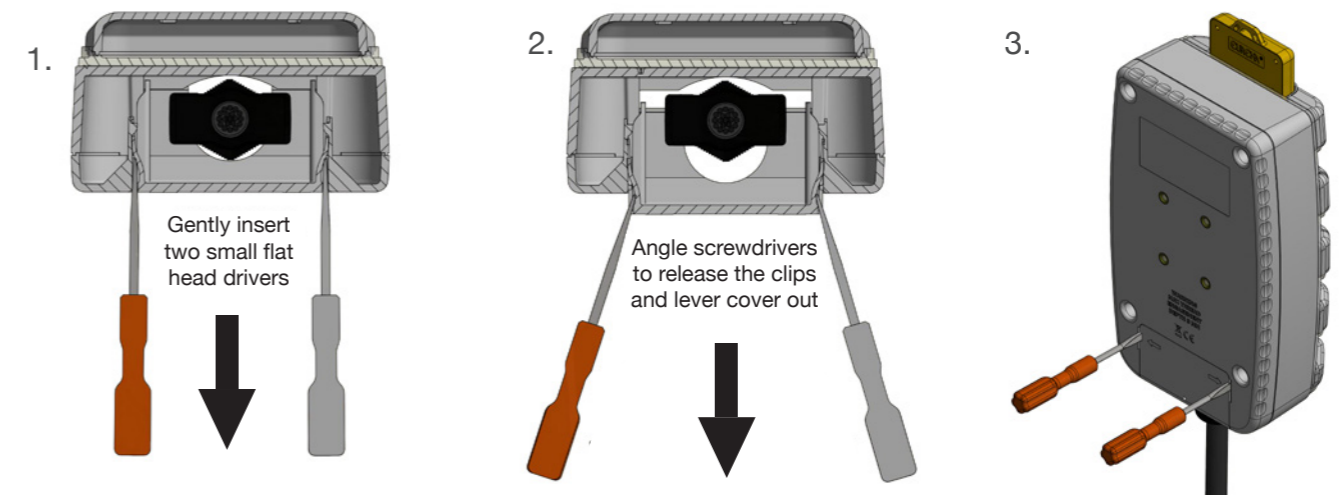

5. Antenna Unit

The Antenna Unit creates a tag detection zone. Antennas should be fitted at appropriate locations to provide an optimum detection zone for a specific application (see Installation Considerations). Each antenna detection zone can be adjusted between 3-10m/10'-33' (a 6-20m/20'- 66' sphere from the unit's centre point).

5.1 What's In The Box

ZoneSafe Antenna Function Unit Components	
	
ZoneSafe Antenna (x1) Part No: 5882	IP67 cable grommets (x3)
	
M4 x 35mm Hex Screw (x6)	6 Way Screw Terminal (x2)
	
Collar cable grip (x2)	

5.2 Specification

ZoneSafe Antenna Unit Specifications		
Electrical	Voltage Current Consumption	12V - 24V DC nom (11-32V max) 2A max (power comes from the main control unit)
Mechanical	Dimensions (incl. glands) Material Weight Connectors Mounting	245 x 105 x 90mm/ 9.6" x 4.1" x 3.5" (9 ⁵ / ₈ " x 4 ¹ / ₈ " x 3 ¹ / ₂ ") ABS / PC 1.4kg Nylon Glands AMPS Configuration
Communications	Wired	RS485
Environment	Ingress Protection Temperature	IP67 -40°C to +85°C/ -40°F to 185°F
Radio	Transmit Frequency Receive Frequency Range	125kHz Region Specific* Transmit: adjustable 3-10m/10'-33' approx. Receive: 50m typ

* 868.3MHz, 902.4MHz, 867.0MHz, 919.0MHz
CE approval: 868.3 MHz
FCC/IC approved version: 902.4 MHz

5.3 Antenna Unit Installation

The Antenna Unit and the Control Unit in the same manner (see System Wiring - Schematic section). Both of these Function Units have specific requirements on where they should be mounted. Please read all the information related to the Function Units you will be installing **before** making a decision on placement.

Ensure that the Antenna Unit's location doesn't interfere with any moving parts on the vehicle. For affixing to the vehicle, there are a number of options (see Fixings). If you are unsure of your unit's installation positions, it would be advisable to do a temporary fit prior to permanent fixing so as to allow for any adjustments.

5.4 Installation Considerations

- Ensure no metal is in front or to the sides of the Antenna Unit (see Antenna Mounting Fig.4 & 5 below).
- Mount in a vertical position.
- Always fit the blanking plug to the final antenna in sequence to ensure IP67 rating is maintained.

5.4.1 Antenna Unit Mounting

Antennas should be mounted vertically (1) but can be mounted horizontally (2). However for best performance, install them vertically. When vertically mounted, Antenna Units are installed in high positions, therefore angle the unit downwards (3).

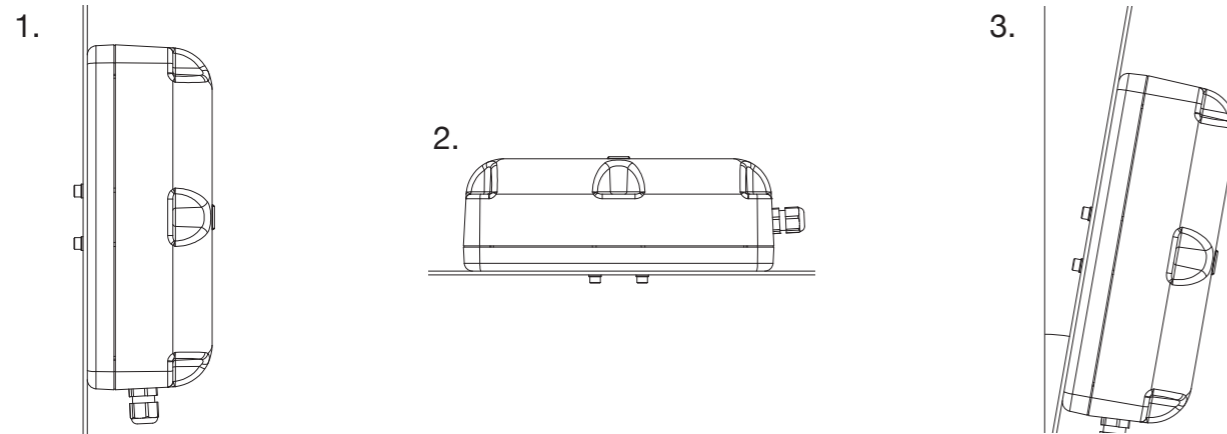

- No metal should be within 200mm/8" of the top, bottom and sides of the Units (4).
- No metal should be in front of the Units (5).

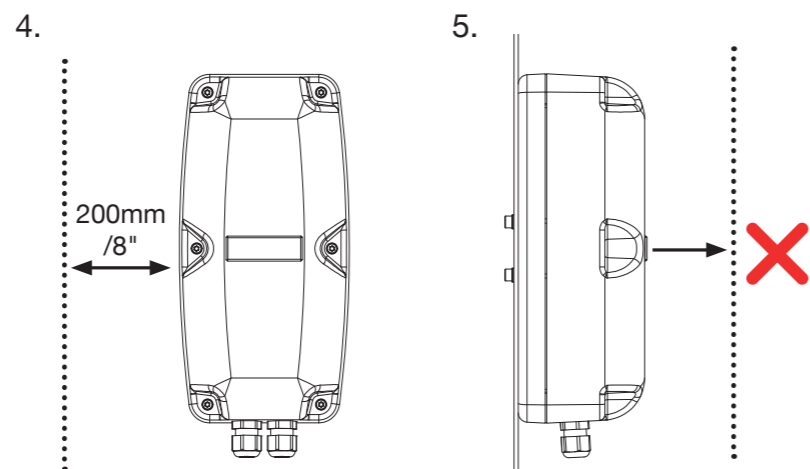

5.4.2 Distance Between Antennas

Choose the size of the detection zone prior to fitting the Antenna Units. The distance between them should equal the detection zone minus 20%. Use the table below to help set up an optimum detection zone. This setup will help to create a uniform array of detection zones.

Detection Zone	10m/33'						
	9m/29.5'						
	8m/26'						
	7m/23'						
	6m/19.5'						
	5m/16.5'						
	4m/13'						
	3m/10'						
		3.2m/10.5'	4m/13.1'	4.8m/15.75'	5.6m/18.4'	6.4m/21'	7.2m/23.6'
Max. Antenna Separation							

5.4.3 Optimum Tag Position

The optimum detection range of the tag can be achieved when the tag and Antenna Unit are level to each other. Changing the angle of the antenna can overcome high mounting issues, but may reduce the effective read range.

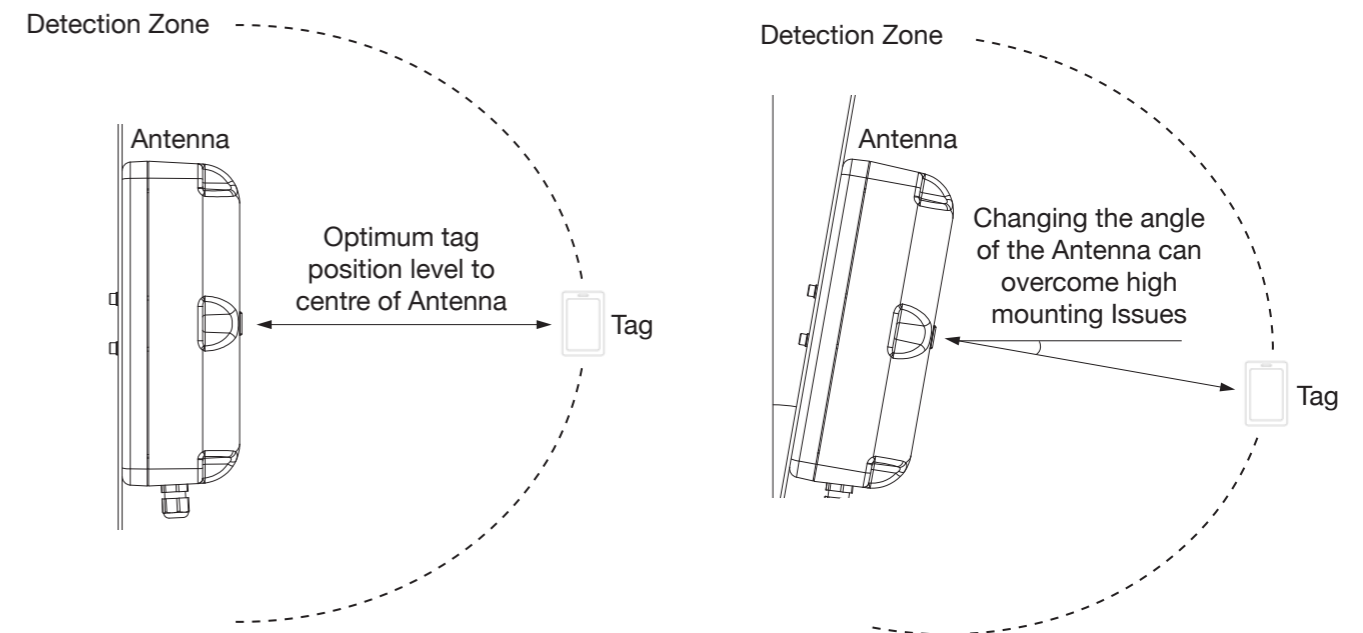

5.4.4 Antenna Unit Example Installation Positions

Depending on the size and shape of the vehicle, more than one antenna may need to be fitted to provide a well defined detection zone.

The below drawings illustrate Antenna Unit placement on various types of vehicles. The larger the vehicle, the more units will need to be fitted in order to create an adequate detection zone around the vehicle. Antenna Units can also be fitted to moving parts (such as the boom or dipper arm of a vehicle) to create a moving detection zone.

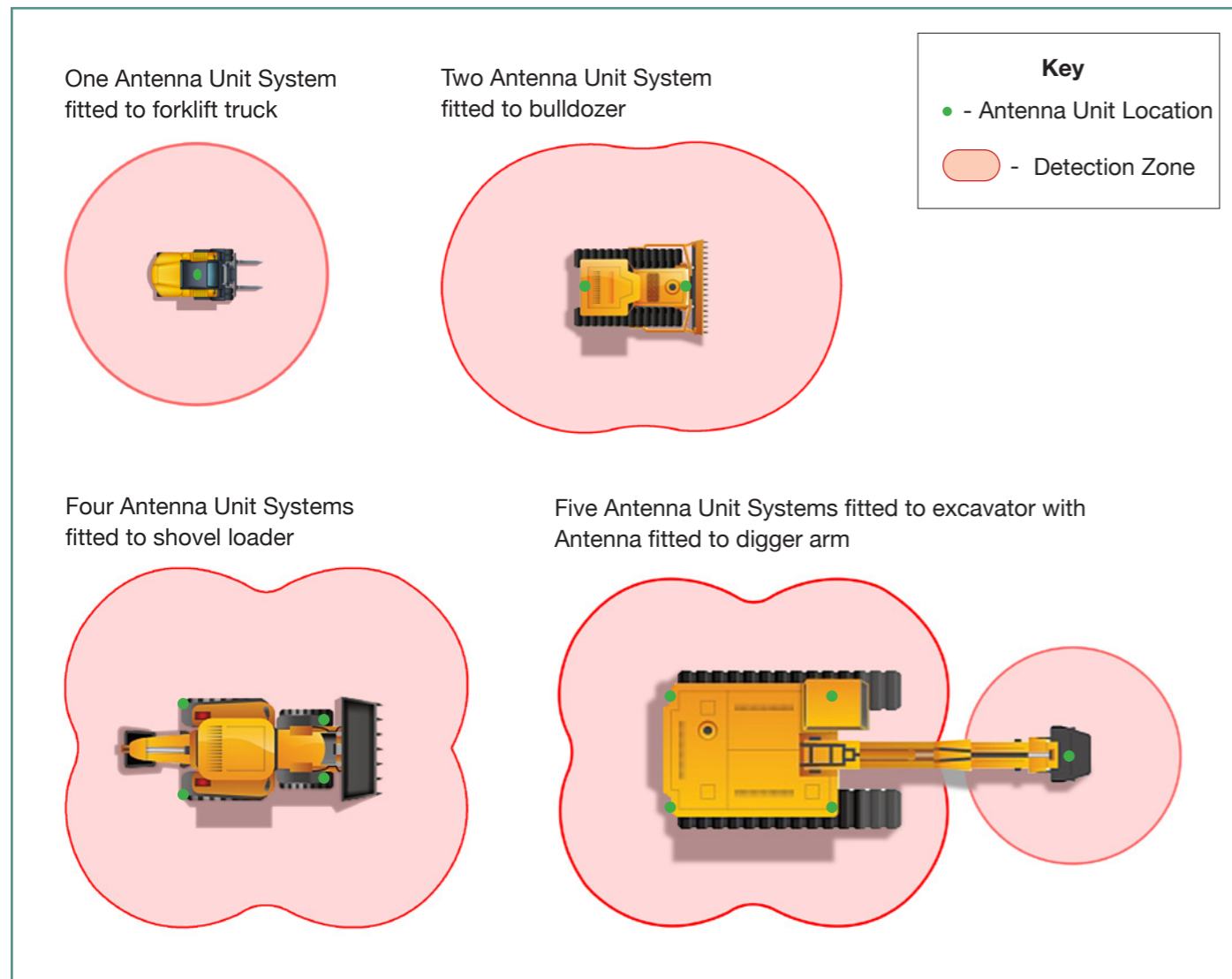

6. Fixings

All ZoneSafe units arrive installed with four M5 threaded inserts in the AMPS hole pattern on the back. These can be fixed directly to mounting plates, which can be fitted to the back of the units.

RAM mounts can be used and we have an additional bracket which has the AMPS hole configuration.

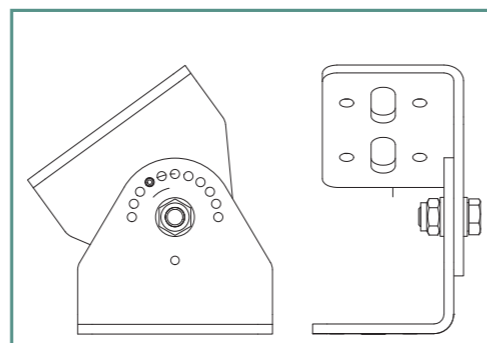

The Adjustable Angle Bracket (ZS-1000-BKT) can be rotated and locked off in one of 11 angled positions.
 Dimensions:
 (w x h x d) 88mm x 88mm x 62mm/
 3.5" x 3.5" x 2.4" (3 1/2" x 3 1/2" x 2 3/8")

6.1 AMPS Hole Configuration

All our units have M5 inserts in the AMPS configuration on the rear. Do not exceed the maximum stated depth.

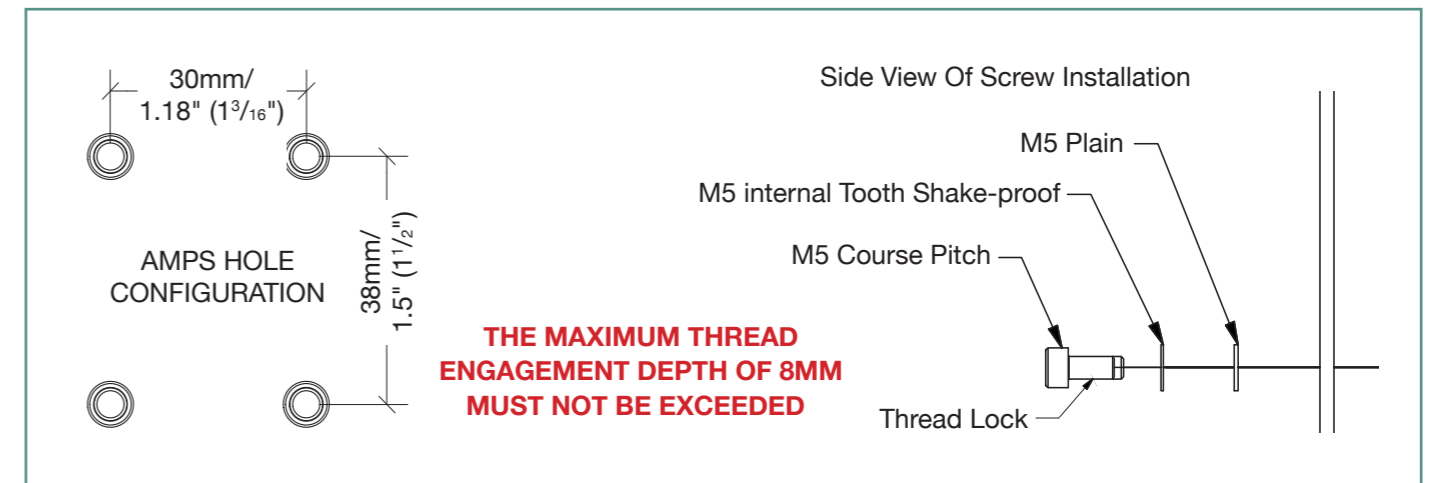

Shake-proof washers are recommended and thread locking liquid can also be used. Fasten securely but do not over-tighten.

6.2 Mounting plates

An adaptor plate is available for all the units. These attach via four countersunk M5 nylon patched screws.

The plates provide slots either on the top and bottom.

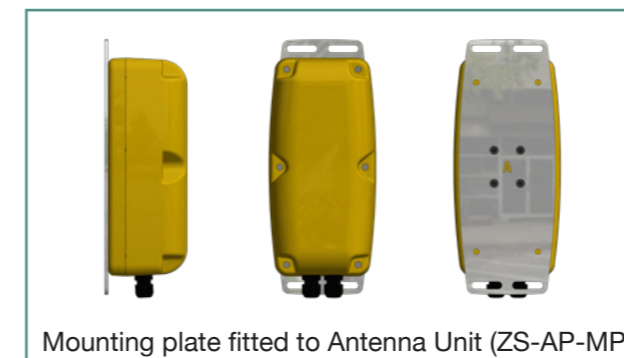
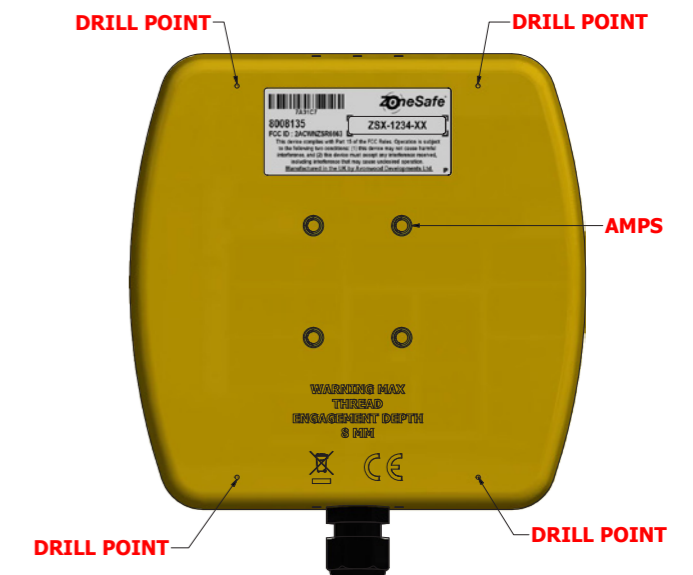

This enclosure also has the option for drilling through the box and fixing using screws or bolts while retaining its IP rating. Max screw/bolt size M4.

7. System Wiring - Schematic

The diagram below demonstrates how the Control Unit and Function Unit/Units are wired to a vehicle and each other.

NOTE: For 12V systems with long cable runs, a separate supply may be required for the Control Unit and each Function Unit. Detection accuracy will depend on environmental and installation factors.

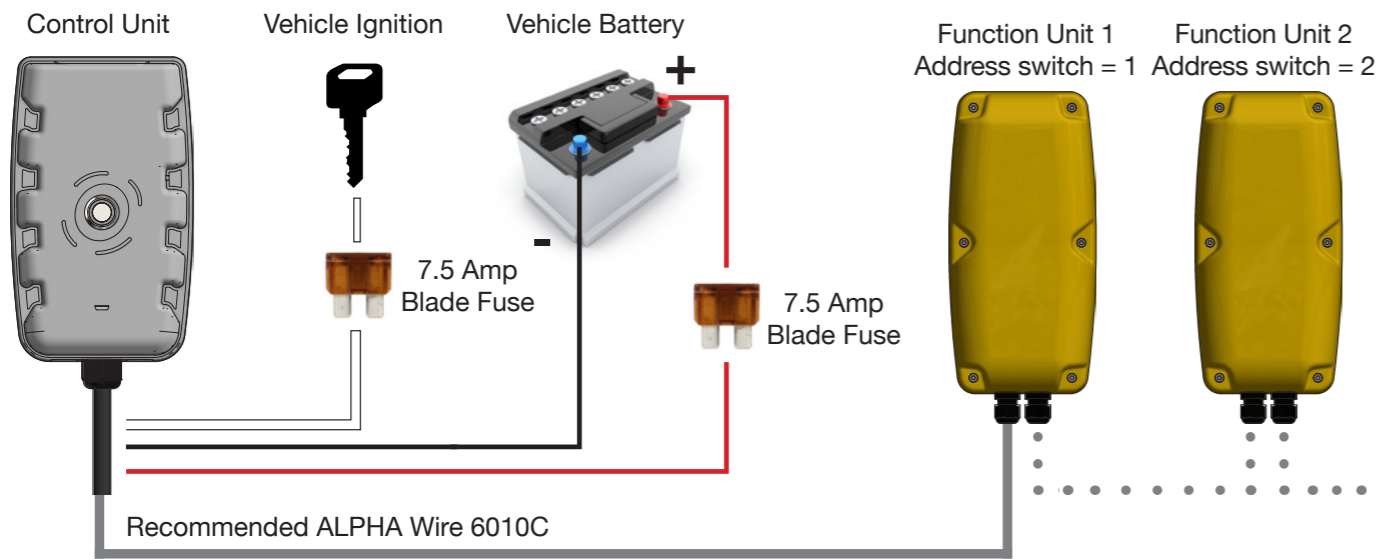

IMPORTANT: Ensure power is isolated & vehicle ignition is OFF before making connections. Replace unused gland on the last Function Unit with a blanking plug. Max distance between each antenna is 30 metres.

Mandatory Wiring Table for the Control Unit cable assembly:

Identifier	Description	Colour	Connect To
VBAT_IN	Vehicle Battery +V IN	Red	Vehicle battery +ve
0V_IN	Vehicle Battery 0V IN	Black	Vehicle battery 0V
VIGN_IN	Vehicle Ignition +V IN	White	Vehicle ignition +ve
0V_OUT	Vehicle Battery 0V OUT	Red/Brown	Function Unit CONN PIN 1
VIGN_OUT	Vehicle Ignition +OUT	Red/Black	Function Unit CONN PIN 2
SYNC_B	Antenna Unit Sync B	Violet	Function Unit CONN PIN 3
SYNC_A	Antenna Unit Sync A	Yellow/Red	Function Unit CONN PIN 4
RS485_B	Function Unit RS485_B	Yellow	Function Unit CONN PIN 5
RS485_A	Function Unit RS485_A	Green/Red	Function Unit CONN PIN 6

Optional Wiring Table:

Identifier	Description	Colour
IN2+	Input 2 Positive	Pink
IN1+	Input 1 Positive	Blue
IN2-	Input 2 Negative	Green
RL_NC	Relay Normally Closed	Orange
RL_NO	Relay Normally Open	Brown
IN3+	Input 3 Positive	Turquoise
IN3-	Input 3 Negative	Grey
IN1-	Input 1 Negative	Red/Blue
RL_COM	Relay Common	White/Red

7.1 Antenna Unit Wiring

Antenna Units are linked together using CONN2 and CONN3 for connection of further antennas as illustrated below in the diagram.

Pin numbering and descriptions for CONN2 and CONN3 are identical. CONN2 can be used for the outgoing cable and CONN3 for the incoming cable or vice-versa.

- Cable: 3 pair individually screened, Core: 7/0.2 (i.e. Belden 8777, Alpha 6010C, Cable Hub/ FS cables 2203PIFRD)

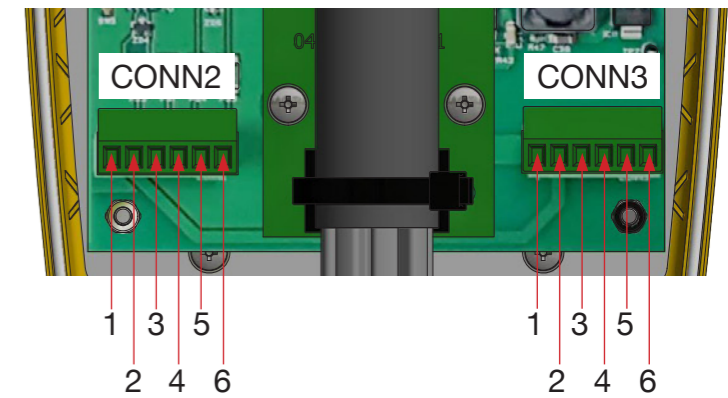

CONN2/3 Pin Number	Description of Wire	Colour*
1	0V_IN	Black/Red
2	VIGN_IN	Red
3	SYNC_B	Black/White
4	SYNC_A	White
5	RS485_B	Black/Green
6	RS485_A	Green

*Wiring Colours Based on Alpha Wire 6010C

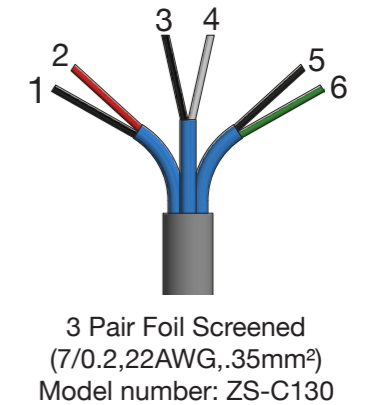

7.2 Antenna Unit Switches

The first switch that needs setting is the address switch SW2. The Function Units need to be numbered sequentially in the order they are wired together, i.e. the first Function Unit connected to the Control Unit should be set to 1, the next one wired to that first Function Unit will be set to 2 and so on.

The second switch is the power setting. Either set SW1 to 0, which is the Wi-Fi setting (recommended), or turn SW1 clockwise to increase power or anticlockwise to decrease power and therefore size of detection zone. If setting SW1 to 0 The range can then be adjusted via Wi-Fi using a mobile smart device such as a mobile phone.

SW2 = ADDRESS. (1=first antenna unit: must be numbered sequentially to the last)

SW1 = POWER. Set 0 for Wi-Fi or manual setting 1(min)-F(max).

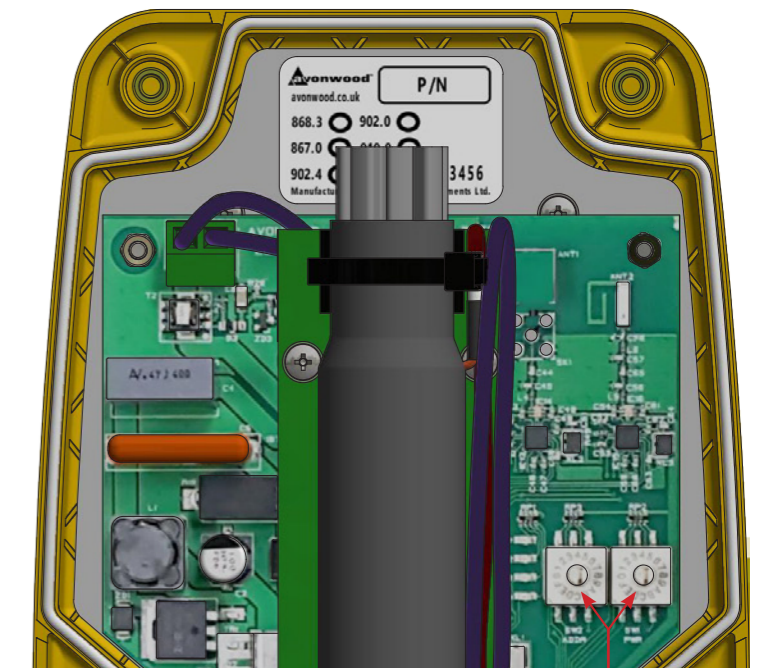
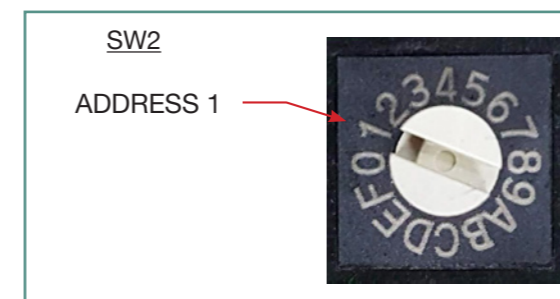
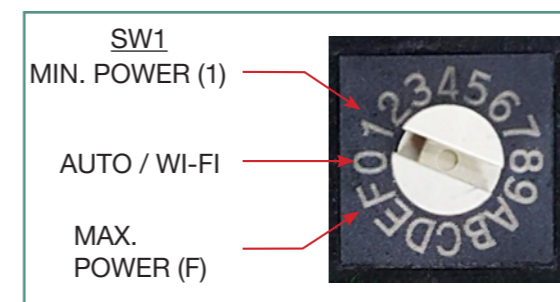

The location of the switches can be found on the top right side, when the unit's cover is removed.

8. Wi-Fi Configuration & Settings

8.1 Control Unit Connection

The Control Unit broadcasts a SSID of ZoneSafe_XXXXXX where XXXXXX is the device's serial number, as printed on the product label on the back of the unit.

From your device, view available Wi-Fi connections and select this network and click Connect. Enter the default security key "ZONESAFE" and click OK.

When the connection has been established, open a web browser and enter URL <http://192.168.0.1/> This is the address of the Control Unit.

When prompted, enter the default user name as "admin" and the password "PASSWORD".

Usernames and passwords are case-sensitive.

8.2 Summary

The Summary page displays the Control Unit and a separate box for each of the Function Units. Click the Settings button on the respective unit to open the configuration page for this unit.

Example serial number located on back of Control Unit.



8.3 View & Change Settings - Control Unit

To change system settings, select the 'Settings' button in the Control Unit section of the SUMMARY page. Settings can be changed in the following sections:

Date/Time

General

Set number of antennas: 1 (only change this if further antennas are added).

Alarm

Set Volume: Low, Medium or High Alarm Time: Number of seconds the alarm continues after tag leaves detection zone Alarm Acknowledge: Disabled, Mute One or Mute All (Mute One is recommended). This is to allow the driver to silence the alarm once a detected tag has been acknowledged. Alarm Tone = Default or Alternative.

Driver

Driver Tag Alarm = Enable (Unit alarms if tag is left in the controller when the ignition is off) ALL other settings should remain as pre-set.

To change antenna settings, select the 'Settings' button in the Antenna section of the SUMMARY page.

Antenna Power

This determines the Antenna power/detection range. Enter: No.1=Min to 15=Max

Note: SW1 on Control Unit must be set to 0 (see 'Antenna switch settings' overleaf)

Important! The system has two range levels which must be set depending on the required detection distance. This setting can be located by following: ADMIN \ GENERAL \ RFID

Relay

Configure how the Control Unit relay will operate. Relay can be activated from a number of sources **and released by mute or acknowledge push button press under selected conditions**

Input

The Antenna Unit can be enabled /disabled via the input 1 signal (either high or low) and the events recorded (see optional wiring table on page 12).

All other settings should only be changed under instruction.

8.4 Settings & Information - Antenna Unit

Antenna Unit Power

Adjust the output power from 1-15, 1 being lowest power.

9. RFID System Operation

9.1 On Sequence

- Place the driver tag into the slot (Where applicable)
- Turn the vehicle ignition ON to initialise the system



- If the Push Button LED = **GREEN** then the system is operational (for any other indication see the alarm table)

- Detection Zone is now **ACTIVE**

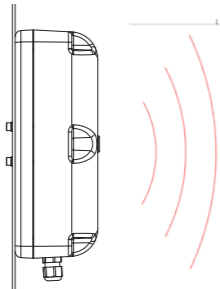

NOTE: If the ignition remains on and no driver tag is detected in the holder for a period of time, the “No Driver Tag” alarm will be raised. This is intended to prevent the vehicle being operated by an unauthorised driver.

9.2 Off Sequence

- Turn the vehicle ignition OFF



- Remove the driver tag from the holder (Where applicable)

- Button LED turns off

- Detection Zone is now **INACTIVE**

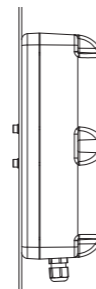
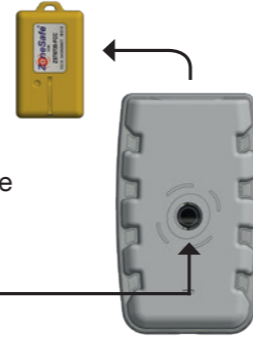

NOTE: If the ignition is off and the driver tag remains in the holder for a period of time, the “No Ignition” alarm will be raised. This is intended to remind the driver to take the tag when leaving the vehicle.

9.3 Control Unit Diagram & Alarm Details

Pedestrian Detection

When a person wearing a ZoneSafe Tag enters the detection zone around a vehicle, the alarm will sound. Press the alarm mute button to silence the alarm.

When two people enter the detection zone wearing a ZoneSafe tag, the alarm will sound twice as fast. The mute button can be configured for various functions using Wi-Fi.

For a full range of alarm sounds, please see below.

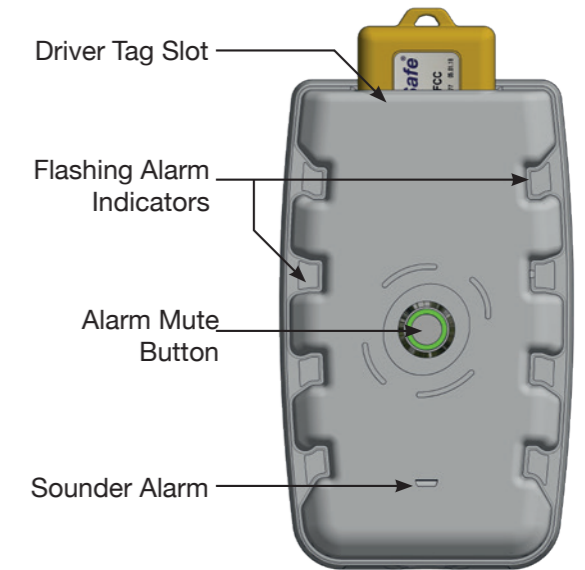

9.4 Types of Alarms

Priority	State	Alarm Colour	Sounder	Button
1	1 Pedestrian	Red Flash Slow	Two Tone Slow	Red
2	2 + Pedestrian	Red Flash Fast	Two Tone Fast	Red
4	System Error	Pink Blip	System Beep	Red
5	No Ignition	Red Pulse	One Tone	Red
6	No Driver Tag	Red Pulse	One Tone	Red
7	Wi-Fi Connected	Blue Pulse	X	Green
8	OK	X	X	Green

9.5 Setup of the Antenna Unit

Detection Zone

- Ensure power switches inside Antenna Units are either set to 0 for Wi-Fi control or a manual power level of 1 - F.
- Using an Active Tag, walk around the detection zone that has been set and measure required size of detection zone.
- Adjust the power settings via Wi-Fi or manually via the switch on the PCB inside the Antenna Unit to set the desired detection zone.
- Set the distance required for the vehicle warning and/or alarm threshold.

10. Troubleshooting

In the unlikely event of a Control Unit warning state, connect to the Control Unit using Wi-Fi direct and view events for more information before reading through this troubleshooting table.

Problem	Solution
Red light pulsing on Control Unit	With the ignition off, the driver tag must be removed within a certain time as this is a warning that the tag has been left in the vehicle.
	With the ignition on, ensure that the driver tag is inserted.
	Check driver tag is inserted correctly (if not using driver tag check disabled in Wi-Fi settings).
	Check alternate driver tag to ensure that the issue is not a faulty tag.
Pink light pulsing on Control Unit	Confirm ignition wiring is correct, check the system wiring table.
	Check Function Unit wiring & configuration.
Pedestrian alarm on Control Unit but no tag is thought to be in range of vehicle.	Make sure Antenna Unit PCB connectors are wired correctly and inserted fully.
	Connect to the Control Unit and view events to identify the tag number the system is detecting. Check to see if this matches the driver tag number, if it does match then either increase the distance between the Antenna Unit and Control Unit or decrease the power of the Antenna Unit.
Two or more vehicles alarm at the same time when just one of them detects a tag.	If the tag number(s) logged in the events does not match the driver tag, then there may be tags that are hidden from view. You can try a combination of moving the vehicle to where it does not alarm, out in the open and away from walls, desks, lockers etc., and reducing the Detection Zone to attempt to locate the problem tag(s).
	Confirm the that the vehicle IDs do not match one another, if they do, change them so they all have a unique number.
Alarm does not mute when button is pressed.	Check the Alarm acknowledge setting in the controller configuration settings. Make sure it is set correctly for your requirements. If it is set to mute a tag alarm and does not mute the alarm then more than one tag is present in the Detection Zone.
There is a constant alarm tone when leaving the vehicle	Remove driver tag or disable driver tag alarm.

If a fault cannot be identified in the above table, or the solution does not resolve your fault, please contact your Zonesafe qualified installation engineer.

It is the responsibility of the end user to keep a record of unique vehicle wake up ID if altered from the manufacture supplied ID.

11. System Units Care

To clean your system units just wipe over with a damp cloth. Do not expose plastics to or clean them with any harsh cleaning chemicals or solvents, as this may damage the casing. Do not expose to a naked flame. System devices contain electronic equipment and in some cases moving parts. Whilst every step has been taken to produce a robust product, it's advisable for longevity that products are treated with care.

12. Disclaimer

The Zonesafe systems is an invaluable driver aid but do not exempt the driver from taking every normal precaution when conducting a manoeuvre. No liability arising out of the use or failure of the product can in any way be attached to Brigade or to the distributor.

